

CONCRETE BLOCK ASSEMBLY - INSTALLATION SUMMARY DIAGRAMS.

*USE ONLY IN CONJUNCTION WITH INSTALLATION INSTRUCTIONS.
READ ENTIRE INSTALLATION INSTRUCTIONS GUIDE PRIOR TO ASSEMBLY*

1. Mark an outline on the floor for the desired location. Make sure there is the required minimum clearance between combustible walls. Anchor base to floor with rebar if required (Earthquake zone only). Begin to lay block.

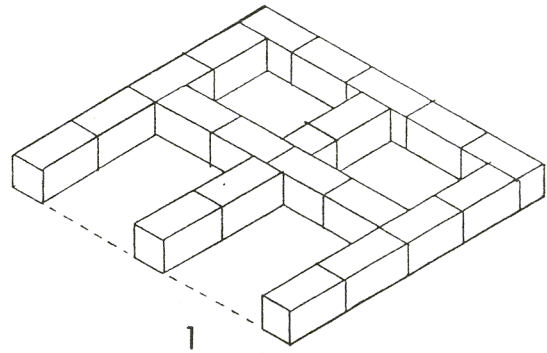

2. Set the first five courses of block. Place vertical and horizontal rebar as specified in installation instructions. Lay 1/16" steel plates in position. Place standard insulation over steel plates. Bend rebar over insulation until parallel. Install 6th course of block.

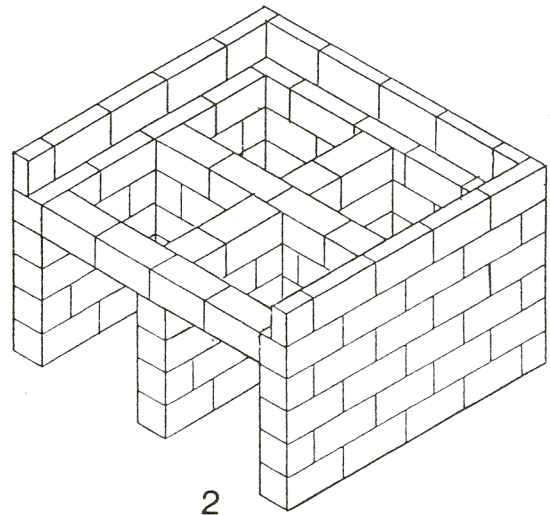

3. Place plywood form to make front shelf. Follow with positioning 1/2" plywood strips (supplied) around perimeter of 6th course to create expansion joint. Lay horizontal rebar. Pour 4" thick concrete slab. Remove plywood strips 2 hours after slab has been poured. Allow concrete to set for 24 hours.

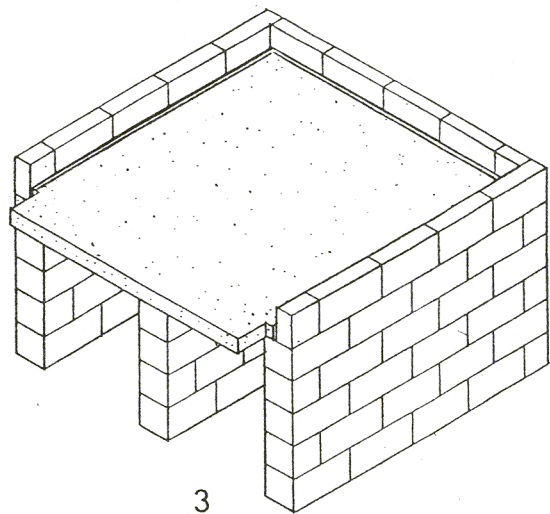

4. Starting from the front center, begin to lay 1" thick lean cement and place floor tiles (supplied) in position. Spread enough lean cement to lay one or two tiles at a time. Keep tiles level and tight. Allow 24 hours to dry. Assemble oven as specified in installation instructions.

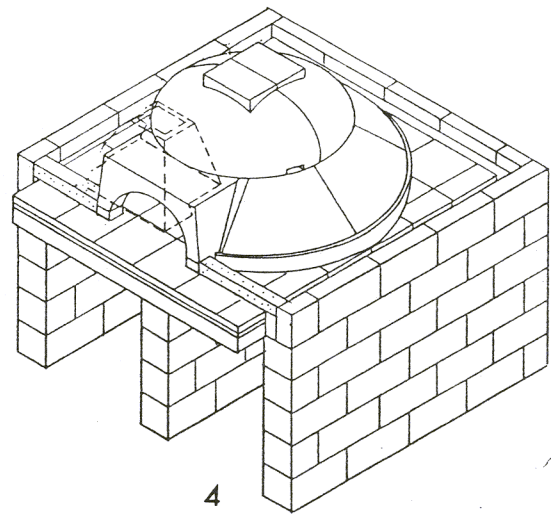

5. Seal all joints and cracks on oven. Follow by placing metal flashing (supplied) over joints as specified in instructions. Set the last 4 courses of block and the courses around the front entrance piece. Fill the cells of the block with concrete. Make sure the top is filled and finished smoothly.

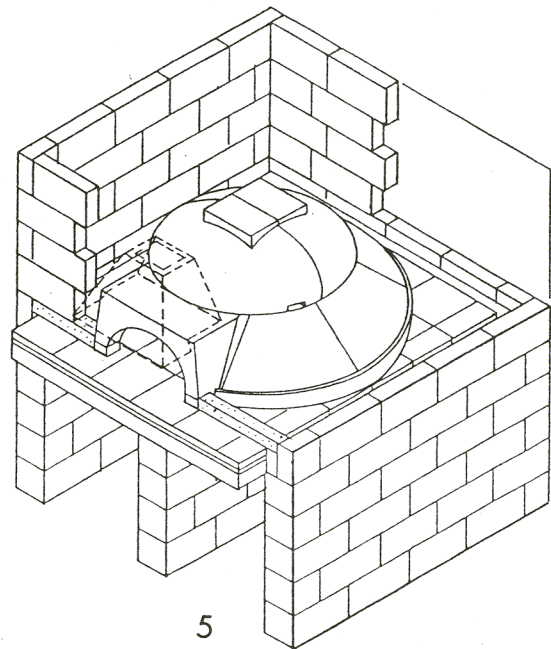

6. Place the temperature gauge and probe (supplied) in proper position. Fill the void between the oven and the concrete block with the insulation mixture as specified. Cover the top with the sheet metal lid. Install acceptable venting application as specified in the installation instructions. Decorate enclosure with non-combustible washable material.

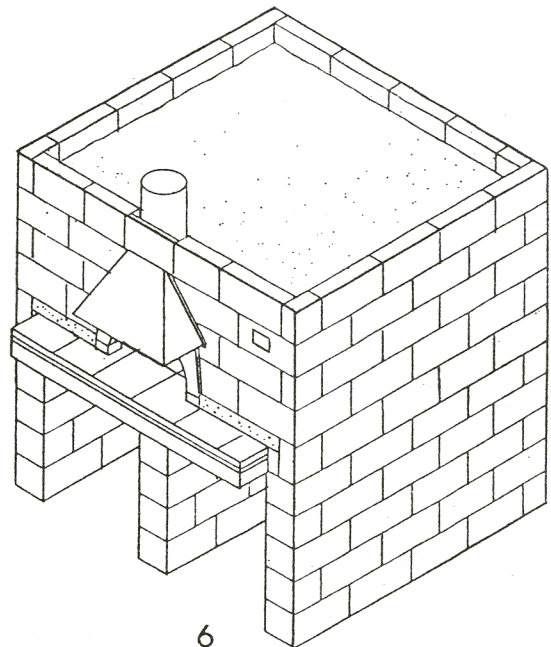

STEEL FRAME ASSEMBLY - INSTALLATION SUMMARY DIAGRAMS

1. Mark an outline on the floor for the desired location. Make sure there is the required minimum clearance between combustible walls (1 inch for side walls and 3 inches above frame). Place lower support stand in position. Place and center horizontal support tubes on vertical support posts and bolt together. This is assembled and shipped together from the factory.

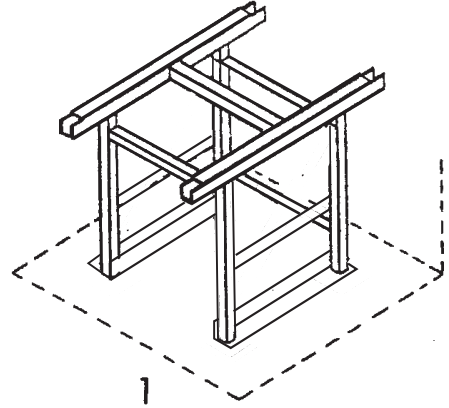

2. Place (horizontal) middle perimeter frame over horizontal support over horizontal support tubes. This may be pre-assembled and shipped from the factory. Place 1/16" thick steel plates over horizontal support tubes (1/2" cement board can be used for exterior applications). The plates should be 1/2" less than the perimeter frame to allow for expansion. Use a smaller piece of steel for the shelf. Follow with placing insulation and rebar (10 ga. wire mesh 6 x 6 can also be used) over top of the plates as specified in the installation instructions.

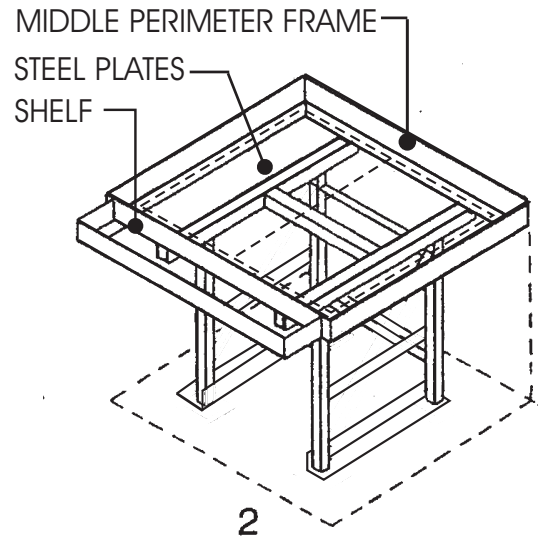

3. Place 1/2" plywood strips (supplied) around the perimeter of the steel frame to create an expansion joint. Pour concrete slab 1/2" from top of middle perimeter frame (Model 90, 110, 130 and 160 about 4" - 4-1/2", Model 60 about 2-1/2" - 3"). Remove plywood strips 2 hours after slab has been poured. Allow concrete to set for at least 24 hours.

1/2" MIN. TO 1" MAX
EXPANSION JOINT

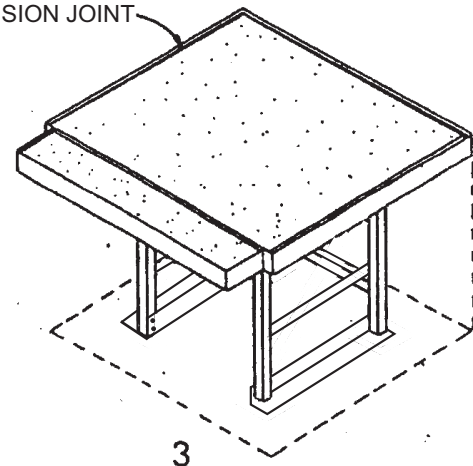

STEEL FRAME ASSEMBLY - INSTALLATION SUMMARY DIAGRAMS

4. Starting from the front center, begin to lay the $\frac{3}{4}$ to 1 inch thick mixture for the floor tile bed. The ratio is 9 parts sand to 1 part cement. Spread enough to lay one or two tiles at a time. Make sure to keep tiles level and tight to each other, no grout is needed between the tiles. Allow 24 hours to dry. Assemble oven as specified in installation instructions. A double thick granite slab, about 1 $\frac{1}{2}$ inches thick, can be used in place of the front row of tiles for a more aesthetic mantle.

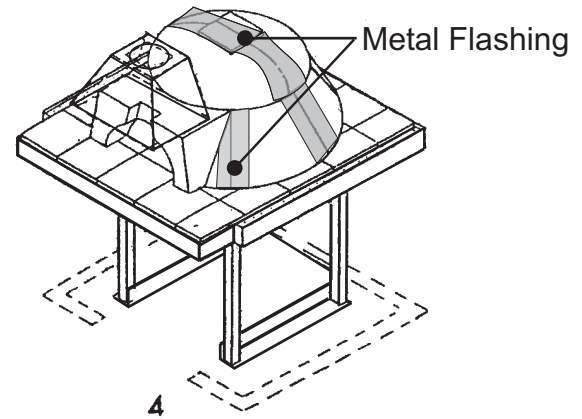

5. Seal all joints on the outside of oven using the bag of refractory cement (supplied). Follow by placing metal flashing (supplied) over oven joints as specified in instructions. Place the two upper halves of the steel frame on the middle perimeter frame and bolt together. (This procedure may have been completed at the factory) Erect metal studs around the lower perimeter of the base and enclose entire frame with cement board.

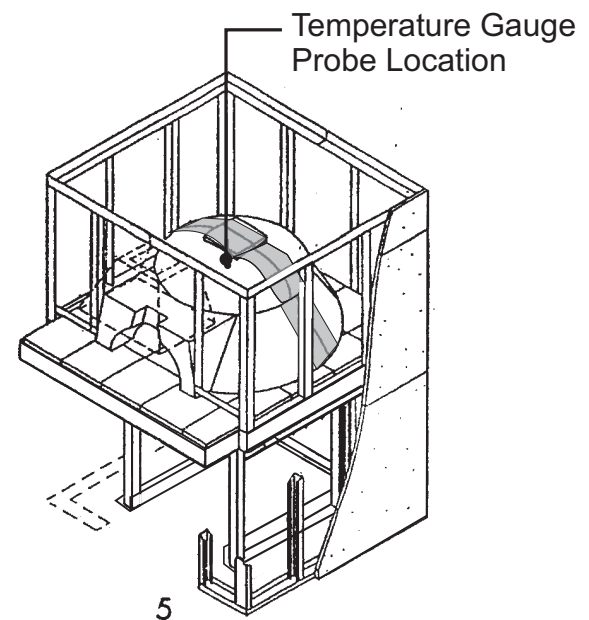

6. Insert metal conduit for temperature probe in the pre-drilled hole located on top of the oven dome. Cover top of conduit with a piece of masking tape. This will prevent insulation and other particles from entering into the hole. Fill the void between the oven and outer enclosure with the insulation mixture as specified. Insulation should cover 4 inches above the oven dome. Make sure to follow oven curing directions in the installation instruction booklet.

